

1.9.3 Consider the function $f : \mathbb{R}^2 \rightarrow \mathbb{R}$ given by

$$f \begin{pmatrix} x \\ y \end{pmatrix} = \begin{cases} \frac{\sin(x^2 y^2)}{x^2 + y^2} & \text{if } \begin{pmatrix} x \\ y \end{pmatrix} \neq \begin{pmatrix} 0 \\ 0 \end{pmatrix} \\ 0 & \text{if } \begin{pmatrix} x \\ y \end{pmatrix} = \begin{pmatrix} 0 \\ 0 \end{pmatrix}. \end{cases}$$

a. What does it mean to say that f is differentiable at $\begin{pmatrix} 0 \\ 0 \end{pmatrix}$?

b. Show that both partial derivatives $D_1 f \begin{pmatrix} 0 \\ 0 \end{pmatrix}$ and $D_2 f \begin{pmatrix} 0 \\ 0 \end{pmatrix}$ exist, and compute them.

c. Is f differentiable at $\begin{pmatrix} 0 \\ 0 \end{pmatrix}$?

Exercise 1.9.3, part c: You may find the following fact useful:

$$|\sin x| \leq |x| \text{ for all } x \in \mathbb{R}.$$

1.10 REVIEW EXERCISES FOR CHAPTER 1

1.1 Which of the following lines are subspaces of \mathbb{R}^2 (or \mathbb{R}^n)? For any that are not, why not?

a. $y = -2x - 5$ b. $y = 2x + 1$ c. $y = \frac{5x}{2}$

1.2 For what values of a and b do the matrices

$$A = \begin{bmatrix} 1 & a \\ a & 0 \end{bmatrix} \quad \text{and} \quad B = \begin{bmatrix} 1 & 0 \\ b & 1 \end{bmatrix}$$

satisfy $AB = BA$?

1.3 Show that if A and B are upper triangular $n \times n$ matrices, so is AB .

Exercise 1.4: If you are not comfortable with complex numbers, please read section 0.7.

1.4 a. Show that the rule associating a complex number $z = \alpha + i\beta$ to the 2×2 matrix $T_z = \begin{bmatrix} \alpha & \beta \\ -\beta & \alpha \end{bmatrix}$ satisfies

$$T_{z_1+z_2} = T_{z_1} + T_{z_2} \quad \text{and} \quad T_{z_1 z_2} = T_{z_1} T_{z_2}.$$

b. What is the inverse of the matrix T_z ? How is it related to $1/z$?

c. Find a 2×2 matrix whose square is minus the identity.

1.5 Suppose all the edges of a graph are oriented by an arrow on them. We allow for two-way streets. Define the oriented adjacency matrix to be the square matrix with both rows and columns labeled by the vertices, where the (i, j) th entry is m if there are m oriented edges leading from vertex i to vertex j .

What are the oriented adjacency matrices of the graphs below?

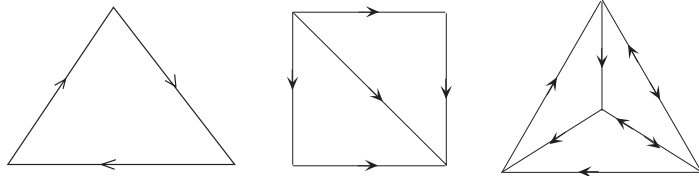

1.6 Are the following maps linear? If so, give their matrices.

$$\text{a. } \begin{bmatrix} x_1 \\ x_2 \\ x_3 \\ x_4 \end{bmatrix} \mapsto \begin{bmatrix} x_2 \\ x_4 \end{bmatrix} \quad \text{b. } \begin{bmatrix} x_1 \\ x_2 \\ x_3 \\ x_4 \end{bmatrix} \mapsto \begin{bmatrix} x_2 x_4 \\ x_1 + x_3 \end{bmatrix}$$

1.7 a. Is there a linear transformation $T : \mathbb{R}^4 \rightarrow \mathbb{R}^3$ such that all of the following are satisfied?

$$T \begin{bmatrix} 1 \\ 0 \\ 1 \\ 0 \end{bmatrix} = \begin{bmatrix} 1 \\ 1 \\ 1 \end{bmatrix}, \quad T \begin{bmatrix} 0 \\ 1 \\ 1 \\ 0 \end{bmatrix} = \begin{bmatrix} 0 \\ 2 \\ 3 \end{bmatrix}, \quad T \begin{bmatrix} 0 \\ 1 \\ 1 \\ 1 \end{bmatrix} = \begin{bmatrix} 2 \\ 1 \\ 2 \end{bmatrix}, \quad T \begin{bmatrix} 1 \\ 0 \\ 0 \\ 1 \end{bmatrix} = \begin{bmatrix} 3 \\ -1 \\ -1 \end{bmatrix}$$

If so, what is its matrix?

b. Let S be a transformation such that the equations of part a are satisfied, and, in addition, $S \begin{bmatrix} 1 \\ 1 \\ 1 \\ 1 \end{bmatrix} = \begin{bmatrix} 0 \\ 3 \\ 2 \end{bmatrix}$. Is S linear?

1.8 Find the matrix for the transformation from $\mathbb{R}^3 \rightarrow \mathbb{R}^3$ that rotates by 30° around the y -axis.

1.9 a. What are the matrices of the linear transformations $S, T : \mathbb{R}^4 \rightarrow \mathbb{R}^3$ corresponding to reflection in the planes of equation $x = y$ and $y = z$?

b. What are the matrices of the compositions $S \circ T$ and $T \circ S$?

c. What relation is there between the matrices in part b?

d. Can you name the linear transformations $S \circ T$ and $T \circ S$?

1.10 Let A be a 2×2 matrix. If we identify the set of 2×2 matrices with \mathbb{R}^4

by identifying $\begin{bmatrix} a & b \\ c & d \end{bmatrix}$ with $\begin{bmatrix} a \\ b \\ c \\ d \end{bmatrix}$, what is the angle between A and A^{-1} ? Under

what condition are A and A^{-1} orthogonal?

1.11 Let P be the parallelepiped $0 \leq x \leq a$, $0 \leq y \leq b$, $0 \leq z \leq c$.

a. What angle does a diagonal make with the sides? What relation is there between the length of a side and the corresponding angle?

b. What are the angles between the diagonal and the faces of the parallelepiped? What relation is there between the area of a face and the corresponding angle?

1.12 Let A be a 3×3 matrix with columns $\vec{a}, \vec{b}, \vec{c}$, and let Q_A be the 3×3 matrix with rows $(\vec{b} \times \vec{c})^\top, (\vec{c} \times \vec{a})^\top, (\vec{a} \times \vec{b})^\top$.

a. Compute Q_A when $A = \begin{bmatrix} 1 & 2 & 0 \\ 0 & -1 & 1 \\ 1 & 1 & -1 \end{bmatrix}$.

b. What is the product $Q_A A$ when A is the matrix of part a?

c. What is $Q_A A$ for any 3×3 matrix A ?

d. Can you relate this problem to exercise 1.4.20?

Exercise 1.12, part c: Think of the geometric definition of the cross product, and the definition of the determinant of a 3×3 matrix in terms of cross products.

1.13 a. Normalize the following vectors:

$$(i) \begin{bmatrix} 2 \\ 1 \\ 3 \end{bmatrix}; \quad (ii) \begin{bmatrix} -2 \\ 3 \end{bmatrix}; \quad (iii) \begin{bmatrix} \sqrt{3} \\ 0 \\ 2 \end{bmatrix}.$$

b. What is the angle between the vectors (i) and (iii)?

1.14 a. What is the angle θ_n between the vectors $\vec{v}, \vec{w} \in \mathbb{R}^n$ given by

$$\vec{v} = \sum_{i=1}^n \vec{e}_i \quad \text{and} \quad \vec{w} = \sum_{i=1}^n i\vec{e}_i?$$

Hint for exercise 1.14: You may find it helpful to use the formulas

$$1 + 2 + \dots + n = \frac{n(n+1)}{2}$$

and

$$1+4+\dots+n^2 = \frac{n(n+1)(2n+1)}{6}.$$

b. What is $\lim_{n \rightarrow \infty} \theta_n$?

1.15 Prove the following statements for closed subsets of \mathbb{R}^n :

a. Any intersection of closed sets is closed.

b. A finite union of closed sets is closed.

c. An infinite union of closed sets is not necessarily closed.

1.16 Show that \bar{U} (the closure of U) is the subset of \mathbb{R}^n made up of all limits of sequences in U that converge in \mathbb{R}^n .

1.17 Consider the function $\mathbf{f} \begin{pmatrix} x \\ y \\ z \end{pmatrix} = \begin{pmatrix} zy^2 \\ 2x^2 - y^2 \\ x + z \end{pmatrix}$, evaluated at $\begin{pmatrix} 1 \\ 1 \\ 1 \end{pmatrix}$. You are given the choice of five directions:

$$\vec{e}_1, \vec{e}_2, \vec{e}_3, \vec{v}_1 = \begin{bmatrix} 1/\sqrt{2} \\ 0 \\ 1/\sqrt{2} \end{bmatrix}, \vec{v}_2 = \begin{bmatrix} 0 \\ 1/\sqrt{2} \\ 1/\sqrt{2} \end{bmatrix}.$$

(Note that these vectors all have length 1.) You are to move in one of those directions. In which direction should you start out

a. if you want zy^2 to be increasing as slowly as possible?

b. if you want $2x^2 - y^2$ to be increasing as fast as possible?

c. if you want $2x^2 - y^2$ to be decreasing as fast as possible?

1.18 The parabola of equation $y = x^2$ is obviously closed, so its complement is open. But it is one thing to say that around every point off the parabola there exists a disc that does not intersect the parabola, and another thing to find the radius of such a disc. Find a formula for the radius r of the largest disc centered at $\begin{pmatrix} 2 \\ 3 \end{pmatrix}$ that doesn't intersect the parabola, using the following steps:

a. Find the distance squared $\left| \begin{pmatrix} 2 \\ 3 \end{pmatrix} - \begin{pmatrix} x \\ x^2 \end{pmatrix} \right|^2$ as a fourth-degree polynomial in x .

b. Find the zeros of the derivative by the method of exercise A2.5.

c. Find r .

1.19 State whether the following limits exist, and prove it.

a. $\lim_{\begin{pmatrix} x \\ y \end{pmatrix} \rightarrow \begin{pmatrix} 0 \\ 0 \end{pmatrix}} \frac{x+y}{x^2-y^2}$ b. $\lim_{\begin{pmatrix} x \\ y \end{pmatrix} \rightarrow \begin{pmatrix} 0 \\ 0 \end{pmatrix}} \frac{(x^2+y^2)^2}{x+y}$ c. $\lim_{\begin{pmatrix} x \\ y \end{pmatrix} \rightarrow \begin{pmatrix} 0 \\ 0 \end{pmatrix}} (x^2+y^2) \ln(x^2+y^2)$

* d. $\lim_{\begin{pmatrix} x \\ y \end{pmatrix} \rightarrow \begin{pmatrix} 0 \\ 0 \end{pmatrix}} (x^2+y^2)(\ln|xy|)$, defined when $xy \neq 0$

1.20 Prove theorems 1.5.28 and 1.5.29.

1.21 Let \mathbf{a}_n be the vector in \mathbb{R}^n whose entries are π and e , to n places:

$\mathbf{a}_1 = \begin{bmatrix} 3.1 \\ 2.7 \end{bmatrix}$, $\mathbf{a}_2 = \begin{bmatrix} 3.14 \\ 2.78 \end{bmatrix}$, and so on. How large does n have to be so that $\left| \mathbf{a}_n - \begin{bmatrix} \pi \\ e \end{bmatrix} \right| < 10^{-3}$? How large does n have to be so that $\left| \mathbf{a}_n - \begin{bmatrix} \pi \\ e \end{bmatrix} \right| < 10^{-4}$?

1.22 For what numbers θ does the sequence of matrices

$$A_m = \begin{bmatrix} \cos m\theta & \sin m\theta \\ -\sin m\theta & \cos m\theta \end{bmatrix}$$

converge? When does it have a convergent subsequence?

1.23 Find a number R for which you can prove that the polynomial

$$p(z) = z^{10} + 2z^9 + 3z^8 + \cdots + 10z + 11$$

has a root for $|z| < R$. Explain your reasoning.

1.24 What is the derivative of the function $f: \mathbb{R}^n \rightarrow \mathbb{R}^n$ given by the formula $f(\mathbf{x}) = |\mathbf{x}|^2 \mathbf{x}$?

1.25 Using definition 1.7.1, show that $\sqrt{x^2}$ and $\sqrt[3]{x^2}$ are not differentiable at 0, but that $\sqrt{x^4}$ is.

1.26 a. Show that the mapping $\text{Mat}(n, n) \rightarrow \text{Mat}(n, n)$, $A \mapsto A^3$ is differentiable. Compute its derivative.

b. Compute the derivative of the mapping

$$\text{Mat}(n, n) \rightarrow \text{Mat}(n, n), A \mapsto A^k, \quad \text{for any integer } k \geq 1.$$

1.27 Which of the following functions are differentiable at $\begin{pmatrix} 0 \\ 0 \end{pmatrix}$?

a. $f \begin{pmatrix} x \\ y \end{pmatrix} = \begin{cases} \frac{x^2 y}{x^2 + y^2} & \text{if } \begin{pmatrix} x \\ y \end{pmatrix} \neq \begin{pmatrix} 0 \\ 0 \end{pmatrix} \\ 0 & \text{if } \begin{pmatrix} x \\ y \end{pmatrix} = \begin{pmatrix} 0 \\ 0 \end{pmatrix} \end{cases}$ b. $f \begin{pmatrix} x \\ y \end{pmatrix} = |x+y|$

c. $f \begin{pmatrix} x \\ y \end{pmatrix} = \begin{cases} \frac{\sin(xy)}{x^2 + y^2} & \text{if } \begin{pmatrix} x \\ y \end{pmatrix} \neq \begin{pmatrix} 0 \\ 0 \end{pmatrix} \\ 0 & \text{if } \begin{pmatrix} x \\ y \end{pmatrix} = \begin{pmatrix} 0 \\ 0 \end{pmatrix} \end{cases}$

1.28 a. Compute the formula for the mapping $A: \mathbb{R}^2 \rightarrow \mathbb{R}$ that gives the area of the parallelogram in \mathbb{R}^3 spanned by $\begin{bmatrix} u \\ 0 \\ u^2 \end{bmatrix}$ and $\begin{bmatrix} 0 \\ v^2 \\ v \end{bmatrix}$.

b. What is $\left[\mathbf{D}A \begin{pmatrix} 1 \\ -1 \end{pmatrix} \right] \begin{bmatrix} 1 \\ 2 \end{bmatrix}$?

c. For what unit vector $\vec{v} \in \mathbb{R}^2$ is $\left[\mathbf{D}A \begin{pmatrix} 1 \\ -1 \end{pmatrix} \right] \vec{v}$ maximal; that is, in what direction should you begin moving $\begin{pmatrix} u \\ v \end{pmatrix}$ from $\begin{pmatrix} 1 \\ -1 \end{pmatrix}$ so that as you start out, the area is increasing the fastest?

d. What is $\left[\mathbf{D}A \begin{pmatrix} 1 \\ 1 \end{pmatrix} \right] \begin{bmatrix} 1 \\ 2 \end{bmatrix}$?

e. In what direction should you move $\begin{pmatrix} u \\ v \end{pmatrix}$ from $\begin{pmatrix} 1 \\ 1 \end{pmatrix}$ so that as you start out, the area is increasing the fastest?

f. Find a point at which A is not differentiable.

Hint for exercise 1.29: Think of the composition of

$$t \mapsto \begin{pmatrix} t \\ t^2 \end{pmatrix} \quad \text{and}$$

$$\begin{pmatrix} x \\ y \end{pmatrix} \mapsto \int_x^y \frac{ds}{s + \sin s},$$

both of which you should know how to differentiate.

Exercise 1.30: It's a lot easier to think of this as the composition of $A \mapsto A^3$ and $A \mapsto A^{-1}$ and to apply the chain rule than to compute the derivative directly.

$$f \begin{pmatrix} x \\ y \end{pmatrix} = \begin{cases} \frac{xy}{x^2 + y^2} & \text{if } \begin{pmatrix} x \\ y \end{pmatrix} \neq \begin{pmatrix} 0 \\ 0 \end{pmatrix} \\ 0 & \text{if } \begin{pmatrix} x \\ y \end{pmatrix} = \begin{pmatrix} 0 \\ 0 \end{pmatrix} \end{cases}$$

Function for exercise 1.32

1.29 a. What is the derivative of the function $f(t) = \int_t^{t^2} \frac{ds}{s + \sin s}$, defined for $t > 1$?

b. When is f increasing or decreasing?

1.30 Referring to example 1.8.6,

a. Compute the derivative of the map $A \mapsto A^{-3}$;

b. Compute the derivative of the map $A \mapsto A^{-n}$.

1.31 Let $U \subset \text{Mat}(n, n)$ be the set of matrices A such that the matrix $AA^T + A^T A$ is invertible. Compute the derivative of the mapping $F : U \rightarrow \text{Mat}(n, n)$ given by $F(A) = (AA^T + A^T A)^{-1}$.

1.32 Consider the function defined on \mathbb{R}^2 given by the formula at left.

a. Show that both partial derivatives exist everywhere.

b. Where is f differentiable?

1.33 Consider the function on \mathbb{R}^3 defined by

$$f \begin{pmatrix} x \\ y \\ z \end{pmatrix} = \begin{cases} \frac{xyz}{x^4 + y^4 + z^4} & \text{if } \begin{pmatrix} x \\ y \\ z \end{pmatrix} \neq \begin{pmatrix} 0 \\ 0 \\ 0 \end{pmatrix} \\ 0 & \text{if } \begin{pmatrix} x \\ y \\ z \end{pmatrix} = \begin{pmatrix} 0 \\ 0 \\ 0 \end{pmatrix}. \end{cases}$$

a. Show that all partial derivatives exist everywhere.

b. Where is f differentiable?

1.34 Let $S \subset \mathbb{R}^2$ be the unit circle, and $h : S \rightarrow \mathbb{R}$ a continuous function such that $h(\mathbf{x}) = -h(-\mathbf{x})$. Define $f : \mathbb{R}^2 \rightarrow \mathbb{R}$ by

$$f(t\mathbf{x}) = th(\mathbf{x}) \quad \text{for } t \in \mathbb{R}.$$

Show that f has directional derivatives in all directions, at all points of \mathbb{R}^2 , but that f is differentiable if and only if there exist $a, b \in \mathbb{R}$ such that $h \begin{pmatrix} x \\ y \end{pmatrix} = ax + by$.

***1.35** What 2×2 matrices A satisfy

$$\text{a. } A^2 = 0, \quad \text{b. } A^2 = I, \quad \text{c. } A^2 = -I?$$

Starred exercises are difficult; exercises with two stars are particularly challenging.

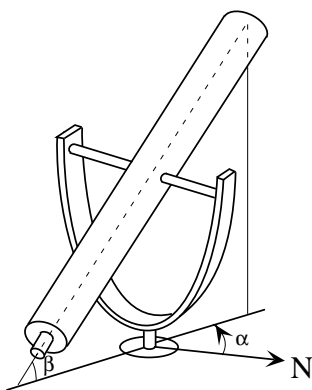

The telescope of exercise 1.37. The angle α is the azimuth; β is the elevation. North is denoted N .

****1.36** (This is very hard.) In the Singapore public garden, there is a statue consisting of a spherical stone ball, with diameter perhaps 1.3 m, weighing at least a ton. This ball is placed in a semispherical stone cup, which it fits almost exactly; moreover, there is a water jet at the bottom of the cup, so the stone is suspended on a film of water, making the friction of the ball with the cup almost 0; it is easy to set it in motion, and it keeps rotating in whatever way you start it for a long time.

Suppose now you are given access to this ball only near the top, so that you can push it to make it rotate around any horizontal axis, but you don't have enough of a grip to make it turn around the vertical axis. Can you make it rotate around the vertical axis anyway?

***1.37** Suppose a telescope is mounted on an equatorial mount, as shown in the margin. This means that mounted on a vertical axis that can pivot there is a U-shaped holder with a bar through its ends, which can rotate also, and the telescope is mounted on the bar. The angle which the horizontal direction perpendicular to the plane of the U makes with north (the angle labeled α in the picture in the margin) is called the azimuth, and the angle which the telescope makes with the horizontal (labeled β) is called the elevation.

Center your system of coordinates at the center of the bar holding the telescope (which doesn't move either when you change either the azimuth or the elevation), and suppose that the x -axis points north, the y -axis points west, and the z -axis points up. Suppose, moreover, that the telescope is in position azimuth θ_0 and elevation φ_0 , where φ_0 is neither 0 nor $\pi/2$.

- What is the matrix of the linear transformation consisting of raising the elevation of the telescope by φ ?
- Suppose you can rotate the telescope on its own axis. What is the matrix of rotation of the telescope on its axis by ω (measured counterclockwise by an observer sitting at the lower end of the telescope)?